

Seatbelt Displacement Sensor SBDS-10V

- Suitable for seatbelt displacement measurement of vehicle, especially to Crash Test;
- Measure resolution: 0.5mm;
- Response up to 50m/s;
- Industrial design and high-quality components;
- High contrast and adhesive stickers;
- Lower power consumption;
- ID Module optional.



Based on light barriers scan, the sensor can measure the linear seat belt movement. For real time, the sensor can convert the result into analog output. There is high performance DC/DC with isolation as power supply. The sensor is good to against ESD and power surge. SBDS-10V includes high quality cables, whose length can be selected. It is also available to Connector and Dallas ID (or TEDS) if needed.

Technical Specification:

(under 10V excitation voltage and 25°C) :

Name	Unit	Value
Range	mm	±1000
Resolution	mm	0.5
Output	V	±2.5
Excitation	V	5-10
Offset	mV/V	<2
Current	mA	<25
Output Res.	Ω	<100
Temperature	°C	0~60
Ambient Light	Lx	<100000
Shock	g	>100
Isolation Res.	MΩ	>100
Status Display	LED	Power/Direction
Mounting	/	2×M4
Case Materials	/	Al. Alloy
Weight	grams	102
Size	mm	70×56×20.7

Default: cable length 8m;

Default: without connector and Dallas ID.

Dimension (mm):

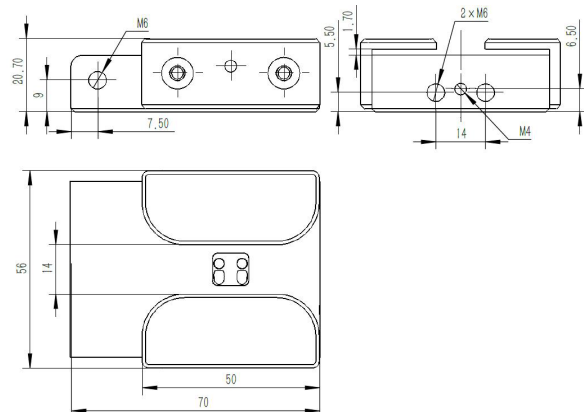

Wires Define:

Red	Excitation+
Black	Excitation-
White	Signal+
Green	Signal-
Shield	Connector Case

Note: Digital Output Version (JEBOOL ADM or Kistler DTI) is optional without Noise.