

# Seatbelt Loadcell SBF-16KN

- Suitable to all kinds of force measurement of Seatbelt;
- Prefer to Crash Test;
- Easy to Mounting;
- 16kN Measurement Range;
- The cable easy to exchange;
- Calibration according to ISO17242;
- Dallas ID Module optional.



Seatbelt force sensor based on full bridge takes the principle of strain and transfers the internal tension of the belt to sensor structure. The strain structure can change resistance different, and then convert it into voltage change. The main structure of sensor is made of titanium alloy material to reduce its weight to other effects. SBF-16kN is equipped with high performance wear cable. Dallas ID and the connector depend on customers.

Technical Specification: (with 10V and 25°C) :

Name	Unit	Value
Range	kN	16
Cubic Fit Error	%	± 0.5 (Typical) ± 1.0 (Max.)
Excitation	V	2~15
ZMO	mV/V	<0.1
Current	mA	<30
Bridge Res.	Ω	350
Isolation Res.	MΩ	>100
Temperature	°C	-20~80
Belt Thickness	mm	≤ 2
Belt Width	mm	≤ 50
Mounting	/	Bars Insert
Material	/	Titanium Alloy
Weight	grams	<70
Dimension	mm	65 × 35 × 16.5

Cable length 8m as default;

LEMO Connector and Dallas ID are optional.

Drawing:

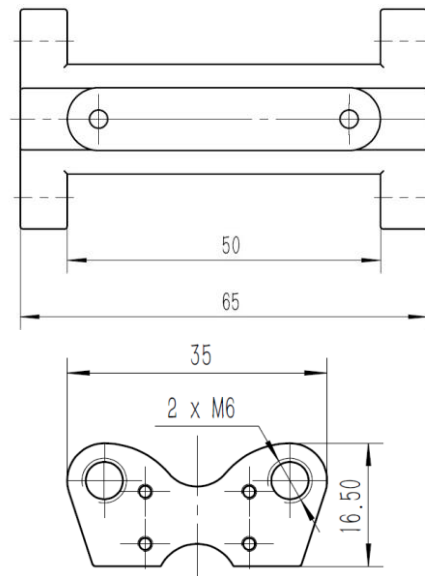

Wires Assignment

Red	EXC+
Black	EXC-
White	SIG-
Green	SIG+
Shield	Case